

RACK MOUNTED

SLIDING GATE OPERATOR

Basic Kit SL1000EVK

Maintenance-free 24 V operator for residential sliding gates with up to 12 meter wide leaf. Modern design combined with powerful technology.



- 1000 kg max. door leaf weight per wing
- 12 m max. door leaf width per leaf**



Popular features

- SMART HOME - myQ compatible operation via smartphone enabled
- Reliable 24V DC motor
- Easy setup and programming
- 3 band multi-frequency radio
- Low standby consumption
- Optional backup battery*

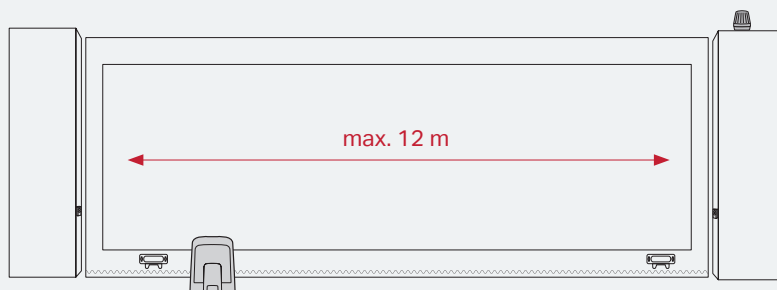

Application: Sliding gate

Content basic kit SL1000EVK

- 1x 24 V sliding gate operator
- 2x 4-channel 868 MHz remote control (TX4EVF)
- 1x control board (built-in) factory preset to required application type. Incl. transformer and built-in radio module (CB324EV)

Extended kits

Content	Kit no.
Basic kit + infrared photocells (772E-01)	SL1000EVK-01
Basic kit + flashing light (FLA1LED)	SL1000EVK-02
Basic kit + infrared photocells (772E-01) + flashing light (FLA1LED)	SL1000EVK-03

Please visit liftmaster.eu for full contents list.

* Limited functionality in battery back-up operation

** 2 leaf application possible via synchronisation function. 2nd sliding gate operator required.

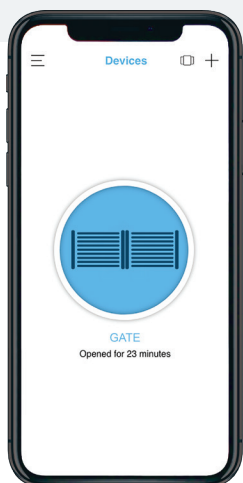

myQ Smart home technology

Monitor and control your drive way gate and LiftMaster EV garage door or myQ LED from anywhere. Get real time notifications, set schedules and share the app with up to five family members and friends.

Never wonder if your gate is left open again.

Required accessories for myQ operation

- Internet gateway (828EV)
- Infrared photocells (772E-01)



Technical specification

Input voltage/frequency	220-240 V AC / 50/60 Hz	Limit switch system	Encoder with magnet
Motor voltage	24 V DC	Working temperature	-20°C to +55°C
Torque/pull force	750 N	Ingress protection	IP 44 (motor)
Max. door leaf width/weight	12 m/1000 kg	Radio frequency	868 MHz range, 433 MHz range, myQ
Max. cycles per hour/day	10/30	Code	Security+ 2.0
Max. opening speed	240 mm/sec	Homelink	Compatible
Standby consumption	4.2 W		

Functions

Smartphone control (myQ)*	Enabled
Battery backup**	With optional battery kit (490EV) (2 x 12V lead acid batteries)
Control board	Built-in
Max. nr. of remotes	180 remotes

Control board functions and connectors:

Automatic force learning, automatic force reversal, soft start/soft stop, force adjustment, speed adjustment, partial opening, timer to close, integrated radio module, 24VDC accessory output, flashing lamp, external input (max. 3), e-lock, magnetic lock, safety edge (8.2 K), external relay, IR's (max. 3), LED display for programming, password protection, maintenance counter.

Connectable accessories

myQ Accessories	myQ gateway (828EV)
Radio Accessories 433 MHz	4 channel transmitter (TX4UNIS), 4 channel transmitter (TX4UNIF), two button wireless wall control for internal use only (128EV), wireless keypad (747EV, 850EV, 780EV)
Radio Accessories 868 MHz	4 channel transmitter (041ATX4EVF), 4 channel transmitter (TX4EVS)
Safety Accessories	IR (772E-01), flashing light (FLA1-LED), 8.2 KOHM safety edge, 2 x 12V lead acid batteries (490EV)
Other Accessories	Key switch (flush mounting 100034, surface mounting 100041), E-Lock 24V (600024), mechanical locking for double swing gates (203339), antenna kit (SWG-ANT-EV)

*Requires usage of a myQ gateway and a presence detecting device (IRs)
** Limited functionality in battery back-up operation

Dimensions

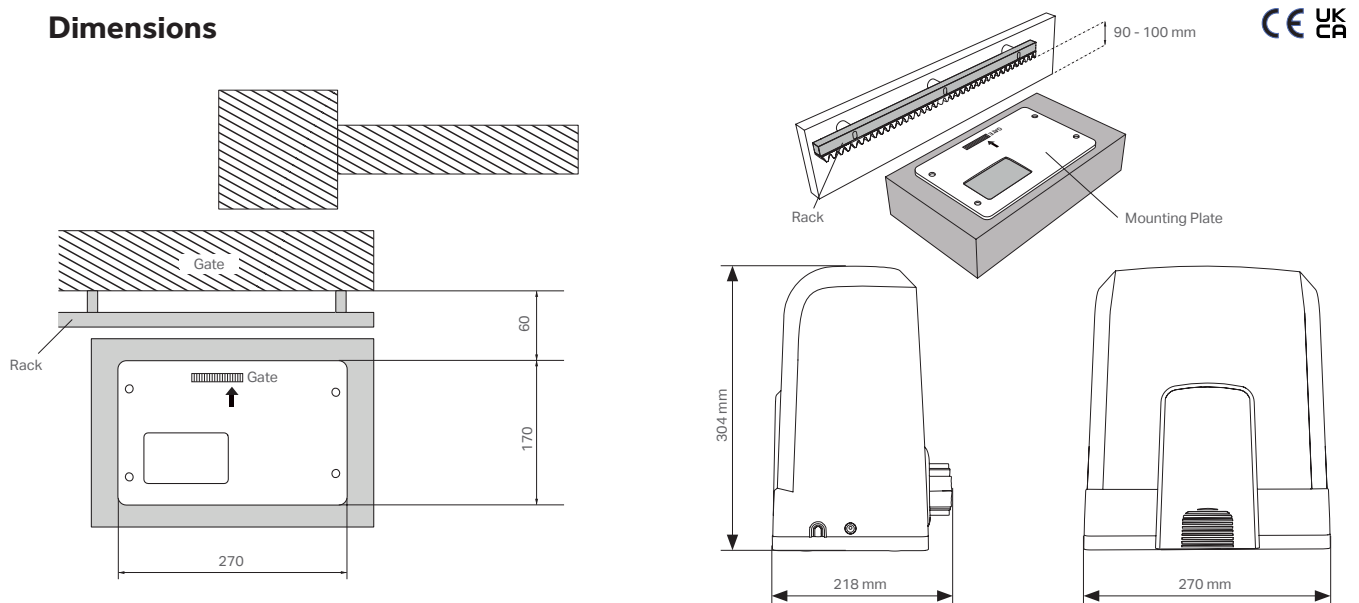

For purchase and professional installation

LiftMaster.eu

For partners

Contact your LiftMaster Representative
Phone Support: 0049 681 870 80 172 | E-Mail: info@chamberlain.com

© 2021 Chamberlain GmbH, All Rights Reserved. | LMSSSL1000EVKV02 7/21 | Misprints, errors and technical changes reserved.

LiftMaster, the LiftMaster logo, myQ, the myQ logo and Chamberlain are registered trademarks of The Chamberlain Group, Inc.
HomeLink® is a trademark of Gentex Corporation | Chamberlain GmbH, Saar-Lor-Lux-Str. 19, D-66115 Saarbrücken

